



**FITTING INSTRUCTIONS FOR MLGFK0017 LEVER-GUARD FITTING KIT
TO FIT SUZUKI YAMAHA T-MAX 530 '17-**

Page | 1



PLEASE ENSURE THAT THIS PRODUCT WILL FIT BEFORE ANY REMOVAL OR
MODIFICATIONS OF PARTS ARE MADE TO YOUR MOTORCYCLE

**THIS KIT CONTAINS THE ITEMS PICTURED AND LABELLED BELOW.
DO NOT PROCEED UNTIL YOU ARE SURE ALL PARTS ARE PRESENT.**

Please note that the way the kit is packed does not necessarily represent the way of mounting to
the bike

THE PARTS SHOWN MAY BE REPRESENTATIVE ONLY (FOR CLARITY OF INSTRUCTIONS ONLY)

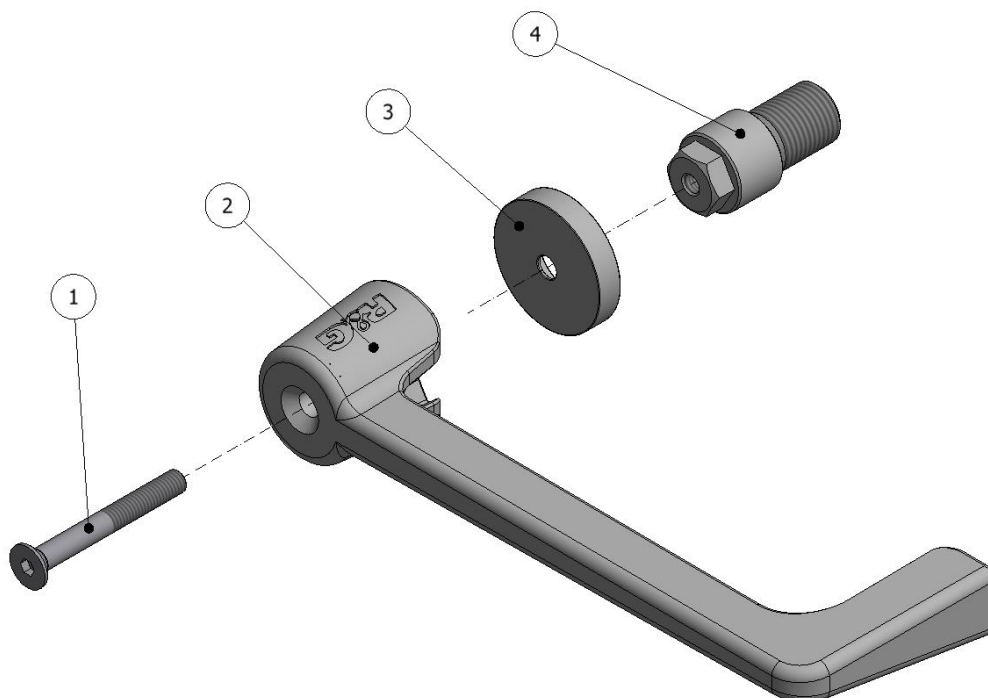

R&G Racing

Unit 1 Shelleys Lane, East Worldham, Alton, Hants GU34 3AQ

Tel: +44 (0)1420 89007 Fax: +44 (0)1420 87301 www.rg-racing.com Email: info@rg-racing.com



LEGEND

ITEM 1 = M6x60mm LONG COUNTER-SUNK BOLT (x1).

ITEM 2 = MOULDED LEVER GUARD (NOT INCLUDED IN FITTING KIT) (LG0003).

ITEM 3 = SPACER (S1048) (x1).

ITEM 4 = THREADED SPACER (M0535) (x1).

TOOLS REQUIRED

- Set of Allen keys to include 4mm A/F.
 - 15mm A/F Spanner or Socket
- Whatever tools required to remove original bar-end if applicable.

FITTING INSTRUCTIONS

- To fit the Lever Guard (item 2) remove the original bar end.
- Insert and tighten the threaded spacer (item 4) into the bar.
- Place the counter-sunk bolt (item 1) through the Lever Guard.
- Locate the assembly into the threaded spacer and position so when the motorcycle is at full lock in both directions it does not contact any other part of the motorcycle.
- Fully tighten the bolt and check operation.

IMPORTANT:- WHEN FITTING THIS PRODUCT IT IS YOUR RESPONSIBILITY TO ENSURE THAT THE PRODUCT IN NO WAY IMPEDES THE OPERATION OF THE MOTOR CYCLE AND IS CHECKED REGULARLY FOR TIGHTNESS AND OPERATION.

FAILURE TO CHECK THE ABOVE COULD RESULT IN SERIOUS INJURY OR DAMAGE.

Digital copies of these instructions are available to download from www.rg-racing.com

ISSUE 1 18/09/2017 (AR)

CONSUMER NOTICE

The catalogue description and any exhibition of samples are only broad indications of the Products and R&G may make design changes which do not diminish their performance or visual appeal and supplying them in such state shall conform to the order. The Buyer acknowledges no representation or warranty (other than as to title) has been given or will apply to the Products other than those in R&G's order or confirmation and the Buyer confirms it has chosen the Products as being of merchantable quality and suitable for its particular purposes. Where R&G fits the Products or undertakes other services it shall exercise reasonable skill and care and rectify any fault free of charge unless the workmanship has been disturbed. The Buyer is responsible for ensuring that the warranty on the motorcycle is not affected by the fitting of the Products. On return of any defective Products R&G shall at its option either supply a replacement or refund the purchase money but shall not be liable if the Products have been modified or used or maintained otherwise than in accordance with R&G's or manufacturer's instructions and good engineering practice or if the defect arises from accident or neglect. Other than identified above and subject to R&G not limiting its liability for causing death and personal injury, it shall not be liable for indirect or consequential loss and otherwise its liability shall be limited to the amounts paid by the Buyer for the Products or the fitting or service concerned. These terms do not affect the Buyer's statutory rights.

R&G RACING RETURNS POLICY (NON-FAULTY GOODS)

Returns must be pre-authorized (if not pre-authorized the return will be rejected). Goods may only be returned direct to us if they were purchased direct from us (customer must prove if necessary). Otherwise to be returned to original vendor. Goods must be in re-sellable condition, in the opinion of R&G Racing. All returns are subject to a 25% restocking and handling fee (25% of the gross value exc. P&P – at the prevailing price at time of purchase). The customer must pay any and all carriage charges. No returns of discontinued products, unless within 14 days of purchase. This policy does not affect your statutory rights and does not refer to faulty goods.

R&G Racing

Unit 1 Shelleys Lane, East Worldham, Alton, Hants GU34 3AQ

Tel: +44 (0)1420 89007 Fax: +44 (0)1420 87301 www.rg-racing.com Email: info@rg-racing.com



**NOTICE DE MONTAGE POUR MLGFK0017 PROTECTION POIGNEE DE FREIN
POUR SUZUKI YAMAHA T-MAX 530 '17-**

Page | 3



VERIFIER QUE LE PRODUIT SOIT COMPATIBLE AVEC VOTRE MOTO AVANT DE DEMONTER QUOI QUE CE SOIT.

Le kit contient les articles exposés ci-dessous, vérifier que toutes les pièces soient présentes avant de procéder au montage.

La façon dont le kit est emballé ne correspond pas forcément à la façon de monter les pièces sur la moto.

LES PARTIES PRESENTEES PEUVENT ETRE UNIQUEMENT REPRESENTATIVES (POUR LA CLARTE DES INSTRUCTIONS UNIQUEMENT)

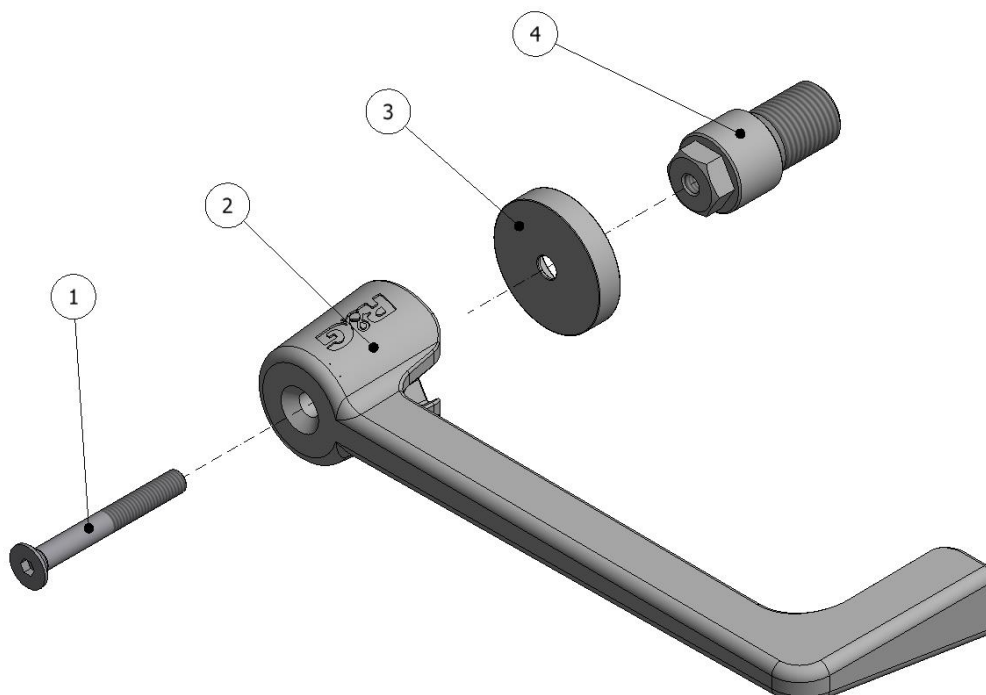



LÉGENDE

ARTICLE 1 = M6x60mm BOULON BO (x1).

ARTICLE 2 = PROTECTION POIGNÉE (NON INCLUSE DANS LE KIT) (LG0003).

ARTICLE 3 = ENTRETOISE (S1048) (x1).

ARTICLE 4 = ENTRETOISE FILETÉE (M0535) (x1).

Page | 4

OUTILS REQUIS

- Clé Allen 4mm.
- Clé à molette 15mm.
- Outil pour Enlever le bouchon de guidon d'origine.

NOTICE DE MONTAGE:

- Pour monter la protection poignée (article 2), Enlever le bouchon de guidon d'origine.
- Insérer puis serrer l'entretoise filetée (article 4) dans le guidon.
- Placer le boulon (article 1) dans la protection poignée.
- Placer l'ensemble dans le guidon et positionnez-le de façon à ce que, lorsque le guidon est tourné au maximum dans les 2 sens, la protection ne touche pas le carénage.
- Serrer complètement le boulon et vérifier le fonctionnement.

IMPORTANT : - IL EST DE VOTRE RESPONSABILITE DE CONTROLER QUE CE PRODUIT NE GENERA PAS LE FONCTIONNEMENT DE LA MOTO, ET DE VERIFIER REGULIEREMENT SON SERRAGE.

NE PAS EFFECTUER CES VERIFICATIONS PEUT CAUSER DES DOMMAGES POUR LA MOTO ET SON PILOTE.

Notice disponible au téléchargement sur www.rg-racing.com

ISSUE 1 18/09/2017 (AR)

CONSUMER NOTICE

The catalogue description and any exhibition of samples are only broad indications of the Products and R&G may make design changes which do not diminish their performance or visual appeal and supplying them in such state shall conform to the order. The Buyer acknowledges no representation or warranty (other than as to title) has been given or will apply to the Products other than those in R&G's order or confirmation and the Buyer confirms it has chosen the Products as being of merchantable quality and suitable for its particular purposes. Where R&G fits the Products or undertakes other services it shall exercise reasonable skill and care and rectify any fault free of charge unless the workmanship has been disturbed. The Buyer is responsible for ensuring that the warranty on the motorcycle is not affected by the fitting of the Products. On return of any defective Products R&G shall at its option either supply a replacement or refund the purchase money but shall not be liable if the Products have been modified or used or maintained otherwise than in accordance with R&G's or manufacturer's instructions and good engineering practice or if the defect arises from accident or neglect. Other than identified above and subject to R&G not limiting its liability for causing death and personal injury, it shall not be liable for indirect or consequential loss and otherwise its liability shall be limited to the amounts paid by the Buyer for the Products or the fitting or service concerned. These terms do not affect the Buyer's statutory rights.

R&G RACING RETURNS POLICY (NON-FAULTY GOODS)

Returns must be pre-authorised (if not pre-authorised the return will be rejected). Goods may only be returned direct to us if they were purchased direct from us (customer must prove if necessary). Otherwise to be returned to original vendor. Goods must be in re-sellable condition, in the opinion of R&G Racing. All returns are subject to a 25% restocking and handling fee (25% of the gross value exc. P&P – at the prevailing price at time of purchase). The customer must pay any and all carriage charges. No returns of discontinued products, unless within 14 days of purchase. This policy does not affect your statutory rights and does not refer to faulty goods.

R&G Racing

Unit 1 Shelleys Lane, East Worldham, Alton, Hants GU34 3AQ

Tel: +44 (0)1420 89007 Fax: +44 (0)1420 87301 www.rg-racing.com Email: info@rg-racing.com



**MONTAGEANLEITUNG FÜR MLGFK0017 BREMSHEBELSCHUTZ -
PASSEND FÜR SUZUKI YAMAHA T-MAX 530 '17-**

Page | 5



BITTE STELLEN SIE SICHER, DASS DIESES PRODUKT FÜR DIE MONTAGE AN IHREM MOTORRAD GEEIGNET IST, BEVOR DIE ENTFERNUNG ODER MODIFIKATION IRGENDWELCHER MOTORRADTEILE VORGENOMMEN WIRD.

ALLE KIT-TEILE SIND UNTEN ABGEBILDET UND GEKENNZEICHNET. BEVOR SIE MIT DER MONTAGE BEGINNEN, ÜBERPRÜFEN SIE, DASS ALLE TEILE VORHANDEN SIND.

Hinweis: Die Verpackung der Teile stellt nicht die Reihenfolge der Montage dar.

DIE UNTEN ABGEBILDETEN TEILE DIENEN LEDIGLICH ZUR ERKLÄRUNG

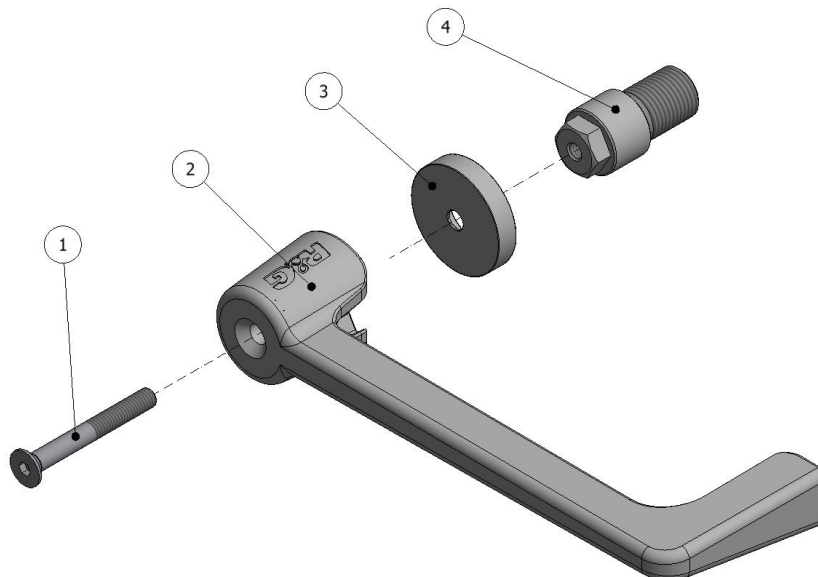

R&G Racing

Unit 1 Shelleys Lane, East Worldham, Alton, Hants GU34 3AQ

Tel: +44 (0)1420 89007 Fax: +44 (0)1420 87301 www.rg-racing.com Email: info@rg-racing.com



LIEFERUMFANG

- ARTIKEL 1 = M6x60mm SENKSCHRAUBE (x1)
 ARTIKEL 2 = BREMSHEBELSCHUTZ (NICHT IM MONTAGEKIT ENTHALTEN) (LG0003)
 ARTIKEL 3 = DISTANZHALTER (S1048) (x1)
 ARTIKEL 4 = DISTANZHALTER MIT GEWINDE (M0535) (x1)

Page | 6

- **SIE BENÖTIGEN FOLGENDES WERKZEUG**
 - Satz Inbusschlüssel mit 4mm Inbusschlüssel
 - 15mm Steckschlüssel und Gabelschlüssel
- Werkzeug, um das original Lenkerende zu entfernen (falls zutreffend)

MONTAGEANLEITUNG

- Um den Bremshebelschutz (Artikel 2) zu montieren, entfernen Sie das original Lenkerende.
- Den Distanzhalter mit Gewinde (Artikel 4) am Lenker einsetzen und befestigen.
- Führen Sie die Senkschraube (Artikel 1) durch den Bremshebelschutz.
- Die Einheit im Distanzhalter mit Gewinde fixieren und so positionieren, dass keine Motorradteile berührt werden, wenn der Motorradlenker in beiden Richtungen komplett eingeschlagen ist.
- Ziehen Sie die Schraube fest und überprüfen Sie die Funktion des Bremshebels.

WICHTIG:- BEI DER MONTAGES DES BREMSHEBELSCHUTZ-KITS LIEGT ES IN IHRER VERANTWORTUNG SICHERZUSTELLEN, DASS DAS PRODUKT DIE ORDNUNGSGEMÄSSE FUNKTION DER BREMSE BZW. DES MOTORRADES NICHT BEEINFLUSST ODER GEFÄHRDET. DIE FUNKTION UND FESTIGKEIT MUSS REGELMÄSSIG ÜBERPRÜFT WERDEN.

DIE NICHTBEACHTUNG DIESES SICHERHEITSHINWEISES KANN ZU SCHWEREN VERLETZUNGEN ODER BESCHÄDIGUNG FÜHREN.

Eine digitale Version dieser Montageanleitung kann auf folgender Seite heruntergeladen werden:

www.rg-racing.com

AUSGABE 1 18/09/2017 (AR)

CONSUMER NOTICE

The catalogue description and any exhibition of samples are only broad indications of the Products and R&G may make design changes which do not diminish their performance or visual appeal and supplying them in such state shall conform to the order. The Buyer acknowledges no representation or warranty (other than as to title) has been given or will apply to the Products other than those in R&G's order or confirmation and the Buyer confirms it has chosen the Products as being of merchantable quality and suitable for its particular purposes. Where R&G fits the Products or undertakes other services it shall exercise reasonable skill and care and rectify any fault free of charge unless the workmanship has been disturbed. The Buyer is responsible for ensuring that the warranty on the motorcycle is not affected by the fitting of the Products. On return of any defective Products R&G shall at its option either supply a replacement or refund the purchase money but shall not be liable if the Products have been modified or used or maintained otherwise than in accordance with R&G's or manufacturer's instructions and good engineering practice or if the defect arises from accident or neglect. Other than identified above and subject to R&G not limiting its liability for causing death and personal injury, it shall not be liable for indirect or consequential loss and otherwise its liability shall be limited to the amounts paid by the Buyer for the Products or the fitting or service concerned. These terms do not affect the Buyer's statutory rights.

R&G RACING RETURNS POLICY (NON-FAULTY GOODS)

Returns must be pre-authorized (if not pre-authorized the return will be rejected). Goods may only be returned direct to us if they were purchased direct from us (customer must prove if necessary). Otherwise to be returned to original vendor. Goods must be in re-sellable condition, in the opinion of R&G Racing. All returns are subject to a 25% restocking and handling fee (25% of the gross value exc. P&P – at the prevailing price at time of purchase). The customer must pay any and all carriage charges. No returns of discontinued products, unless within 14 days of purchase. This policy does not affect your statutory rights and does not refer to faulty goods.

R&G Racing

Unit 1 Shelleys Lane, East Worldham, Alton, Hants GU34 3AQ

Tel: +44 (0)1420 89007 Fax: +44 (0)1420 87301 www.rg-racing.com Email: info@rg-racing.com